



Q gateway 5.5 direct

Q gateway 5.5 direct is the optimal solution for the simple and cost-effective changeover from Q walk-by systems to remote readout via Q AMR.

New systems can also be equipped at any time. The gateway receives all QUNDIS measuring devices in C-mode as well as wM-Bus compatible, uni-directional measuring devices from other manufacturers in the direct reception range. A total of up to 1,000 measuring devices* per gateway can be received directly and transmitted to the QUNDIS smart metering platform Q SMP via encrypted 2G / 3G / 4G mobile radio transmission.

The device is equipped with a SIM card at the factory. The configuration of the Q gateway 5.5 direct can be done via the Q SMP.

Q gateway 5.5 direct of the type RNG5 xxxT 2xxx are battery-operated. The mains-operated version RNG5 xxxT 1xxx is available for daily readout.

In addition to a variant for indoor use, QUNDIS offers a variant for extended ambient conditions with protection rating IP65.

* Details according to the service descriptions for gateway services

Features and functions

The Q gateway 5.5 direct combines automated secure internet connection via 2G / 3G / 4G mobile radio and secure bidirectional radio networking in the smart meter subsystem.

The storage of consumption data and status data, intelligent management and control of measuring devices, configuration and diagnosis of the Q gateway 5.5 direct are cloud-based and controlled via the Q SMP. Only a web browser is required for use.

By using high-performance batteries and extremely low power consumption, gateways of the type RNG5 xxxT 2xxx achieve a service life of up to 10 years. This makes the Q gateway 5.5 direct to the ultimate solution for applications and projects that require complete energy autonomy. The system contributes to significant savings in time, effort and cost, and the quality of the services leads to an increase in customer satisfaction.

- ▶ Wireless M-Bus 868 MHz
- ▶ excellent ISM radio reception
- ▶ 2G / 3G / 4G mobile transmission
- ▶ secure mobile data transfer via mobile communications
- ▶ highest possible wireless connectivity through national and international roaming
- ▶ automatic selection of the optimal network guarantees maximum operating time
- ▶ Battery operation, designed for up to 10 years - depending on the operating scenario, 5 years guaranteed in accordance with the Terms and Conditions QUNDIS Gateway Service Description (GSD-II valid from 01.01.2020)
- ▶ integrated GSM and ISM antennas
- ▶ pre-installed SIM card and independent configuration of key parameters
- ▶ wall mounting indoors
- ▶ easy installation at the site
- ▶ management via Q SMP (QUNDIS Smart Metering Platform)

Type overview

Type*	Power supply	Type*	Housing variant
RNG5 xxxT 2xxx	Battery	RNG5 xx2T xxxx	Indoor
RNG5 xxxT 1xxx	Mains connection	RNG5 xx1T xxxx	for extended ambient conditions

* x = variable option code

General information and user interfaces

- ▶ LC display
- ▶ Two-colour optical LED display (red/green)
- ▶ Buzzer: 4 kHz, 75 dB

Technical data

	<p>QUNDIS GmbH hereby declares that the Q gateway 5.5 direct complies with Directives 2014/53/EU (RED) and 2011/65/EU (RoHS). The full text of the EU declaration of conformity is available at the following Internet address: www.qundis.com</p>
---	--

Ambient conditions

Protection rating	RNG5 xx2T xxx RNG5 xx1T xxx	IP42 according to EN 60529 IP65 according to EN 60529
Protection class	RNG5 xxxT 2xx RNG5 xxxT 1xx	III according to EN 61140 II according to EN 61140
Transport		-25 °C ... 70 °C, < 95 % r.F. (without condensation)
Storage		-5 °C ... 45 °C, < 95 % r.F. (without condensation)
Usage	IP42 IP65	-5 °C ... 55 °C, < 95 % r.F. (without condensation) -20 °C ... 55 °C, < 95 % r.F. (without condensation)

Standards

Interference resistance and interference emission	EN 301 489-1, EN 301 489-3
Security	EN 62368-1, EN 62311
RoHS compliant	EN IEC 63000

ISM version

Wireless M-Bus - supported mode	C/T-Mode (EN 13757-4)
Output power	none
RSSI signal strength measurement	yes
Encryption	Security Mode 5 and 7 according to EN 13757-7, Security Profile A and B according to OMS specification
Radio frequency	EN 300 220-2 C-Mode (868,95 +/- 0,25) MHz

2G / 3G / 4G version

Radio frequency	Maximum output power
2G 900 MHz; 1800 MHz	Class 4 (33 dBm +/- 2 dB)
3G 900 MHz (B8); 2100 MHz (B1)	Class 3 (24 dBm + 1/-3 dB)
4G 700 MHz (B28A); 800 MHz (B20); 900 MHz (B8); 1800 MHz (B3); 2100 MHz (B1); 2600 MHz (B7)	Class 3 (23 dBm +/- 2 dB)
GSM and ISM antennas	fully integrated high-performance GSM and ISM antennas

Supply type RNG5 xxxT 2xxx

Battery type	Lithium metal (non-rechargeable)
Nominal voltage	3,0 V
Battery life	designed for up to 10 years - depending on the operating scenario, 5 years according to QUNDIS gateway service agreement description (GSD-II valid from 01.01.2020) guaranteed

Supply type RNG5 xxxT 1xxx

Nominal voltage	AC 100..240 V 50/60 Hz
-----------------	------------------------

Material

Dimensions (WxHxD)	203 mm x 209 mm x 58,5 mm
Weight	RNG5 xxxT 2xxx 1105 g RNG5 xxxT 1xxx 691 g
Housing material	Polycarbonat (PC) + ABS plastic
Mounting material	2 dowel S6 2 Torx 20 screws 4.0 mm x 40 mm 1 Seal

Dimensional drawings type RNG5 xxxT 1xxx

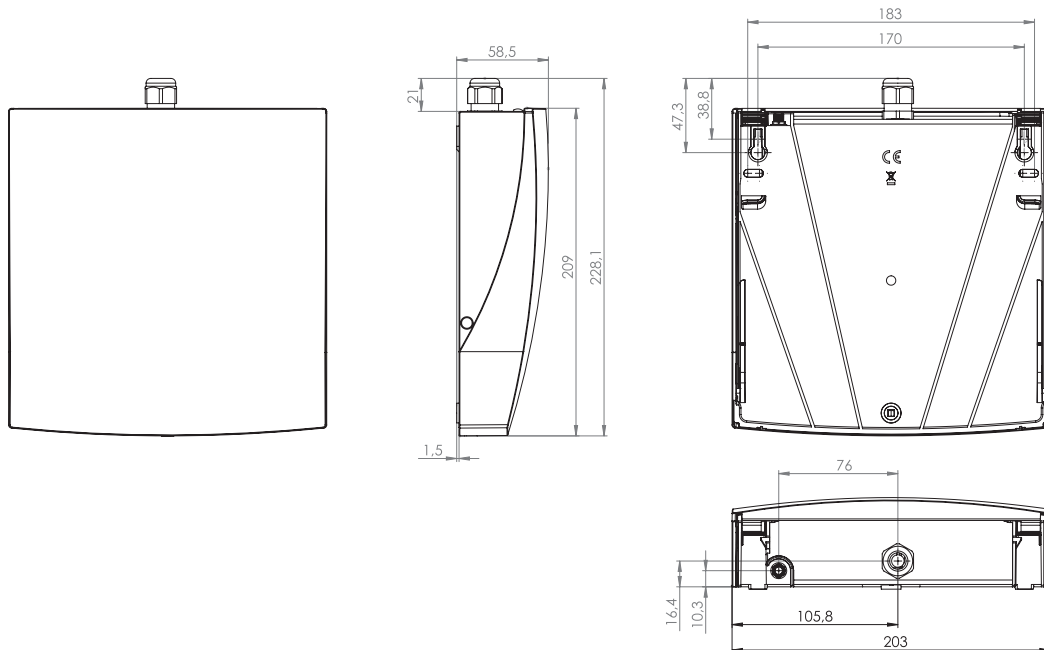

Dimensional drawings type RNG5 xxxT 2xxx

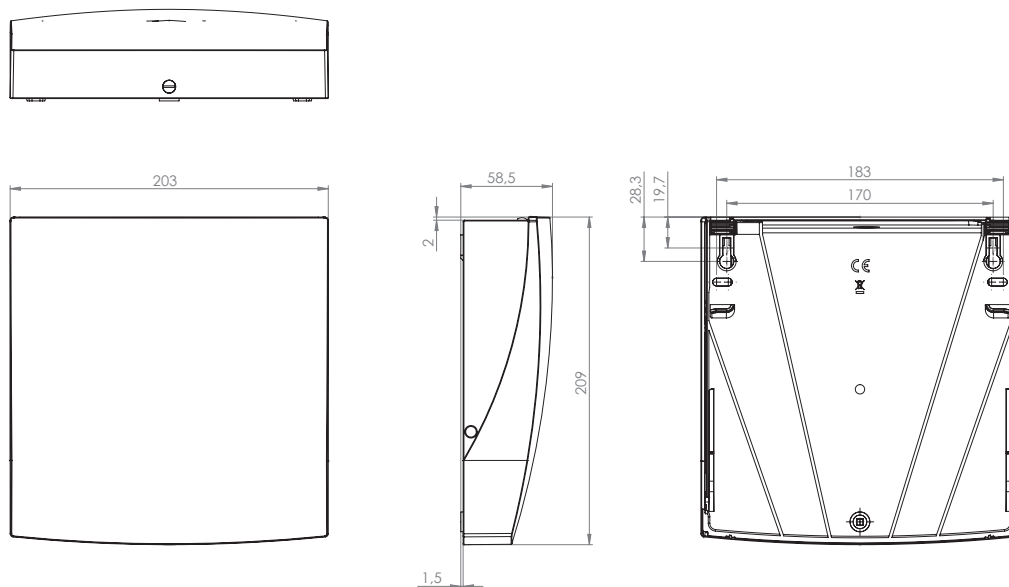

✉ **QUNDIS GmbH**
 Sonnentor 2
 99098 Erfurt, Germany
 ☎ +49 (0) 361 26 280-0
 📠 +49 (0) 361 26 280-175
 📧 info@qundis.com
www.qundis.com

The information in this data sheet contains only general descriptions or performance features which do not always apply in the form described in the specific application or which may change as a result of further development of the products. The desired performance features are then binding if they are expressly agreed upon conclusion of the contract.

© 2023 QUNDIS GmbH. Subject to change without notice